



PF2TT – TABLETOP POWDER FILLER

Cozzoli's PF2 Table Top Powder Filler is designed to promote the highest level of performance for both accuracy and repeatability. This precision powder filler will fill 50mg to 75grams of powder in a single dose, with an accuracy of up to $\pm 1\%$ of fill volume, depending on powder characteristics. Output speeds of 30 containers per minute can be achieved based upon operator dexterity. The compact size is designed for clean rooms, and is ideal for a lab or small production facility.

www.cozzoli.com

50 Schoolhouse Rd., Somerset, NJ 08873 | 732.564.0400 | Sales@Cozzoli.com

OPERATING PRINCIPLE

By applying a predetermined amount of vacuum to the dosing chamber, the powder is drawn in until the dosing chamber is full (see diagram on back). The vacuum cuts off and the pinch valve opens, creating a pathway between the chamber and the filling head. Positive pressure is then applied to the chamber, sending the powder through the dosing head and into the container.

The system's powder pathway is completely enclosed, preventing possible external contamination. When the dosing process is completed, a brief high pressure pulse cleans residue powder from within the dosing chamber and filter, directing it into the container, thus preventing product waste. This innovating filling process operates on a principle requiring no scraper blades or particle-generating components that could contaminate sensitive sterile products.

FEATURES

The unique dual-level supply hopper and agitator provides sufficient material of uniform density to supply the dosing chamber of each filling head. The exclusive filter purging operation minimizes waste, and the microprocessor controls powder pick-up time with minimum speed loss. The PF2TT can also be programmed for multiple dosing for larger fill volumes.

COZZOLI EXCLUSIVES

- Liquid media validation capability greatly simplifies powder media testin.
- Automatic filter cleaning operation eliminates filter purging waste.
- Totally enclosed powder pathway from hopper to vial prevents external contamination.
- Simple fill volume adjustments can be individually fine-tuned without tools or stopping operation.
- Multiple dosing capability.

Each dosing head is equipped with a high-quality microporous membrane filter with a 1micron absolute rating, preventing even the smallest product fines from penetrating and clogging the back side. The filter resists delamination even under high purging pressures, producing more consistent fills over a longer period of time.

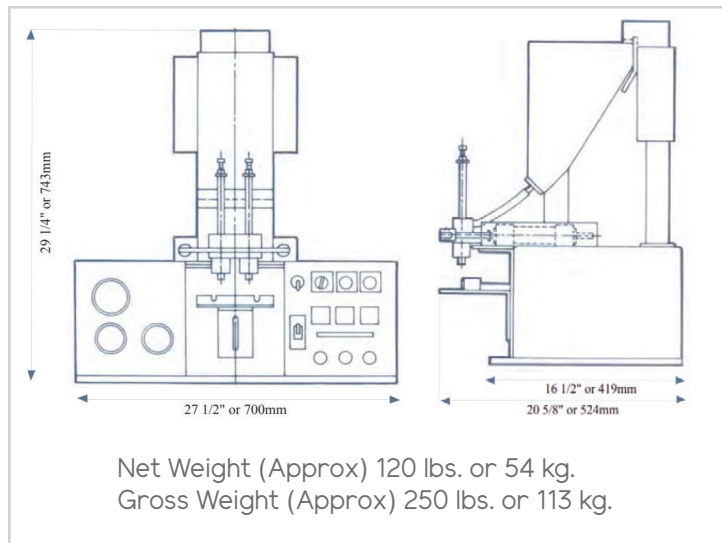

STANDARD FEATURES

- 304 Stainless Steel Exterior Top and Front Cover
- Contact Parts are 316 Stainless Steel,
- Medical Grade Silicone Tubing & Lexan
- Aluminum Frame
- 2 Dosing Heads
- Microprocessor Controls
- 115V/60Hz/1Ph Utilities
- Compressed Air: 60 psi, 10 cfm
- Filter Replacement Kit
- Maintenance & Operation Manual

OPTIONAL FEATURES

- Dosing Head Sizes: 3/16" to 3/4" ID Hopper Mounted
- External Vibrator
- Filter Replacement Kits
- Spare Parts Kit
- IQ/OQ Protocol
- PQ Protocol
- Factory Acceptance Protocol