



RFPC – ROTARY FILLING, PLUGGING AND CAPPING

This versatile monoblock machine can fill, plug and screw cap up to four containers at a time with speeds up to 200 containers per minute, performing each of the operations in synchronization on a common frame—all in less than 45 sq. ft. (4.2m²) of floor space. It's a frequent choice for use in Class 100 clean rooms where the efficient use of space is of prime importance.

◀ www.cozzoli.com ▶

50 Schoolhouse Rd., Somerset, NJ 08873 | 732.564.0400 | Sales@Cozzoli.com



The RFPC is PLC controlled and features a stainless steel exterior and all liquid contact parts of 316L stainless steel. It has a raised sanitary conveyor that transports containers to and from the filling/plugging/capping area and comes with a no plug/no cap detection system. Optional features include servo driven torque heads, over/under torque container rejects system, statistical torque value reporting, no plug/no cap reject system and make up/back up detection systems.

The low profile frame, remote plug and cap pick up stations and open flow through design of the central starwheel are instrumental in enhancing the passage of laminar air flow and minimizing turbulence. The only moving parts over open containers are the filling nozzles. The RFPC series can handle various container shapes and sizes and a wide range of products from aqueous to heavy oils, suspensions and creams.

LIQUID CONTACT MATERIALS

- Set of SS 316L Custom Designed Nozzles
- Set of SS 316L Slide Valves and syringes
- Tygon Intake and Delivery Tubing

PLUG CONTACT MATERIALS

316 Stainless Steel Pick Up Rods, Feed Track, Vibratory Feed Bowl and Collets.

CAP CONTACT MATERIALS

304 Stainless Steel Pick Up Rods, Feed Track, Vibratory Feed Bowl, Pre-Torque Collet(s), and Torque Collet(s) with Non-Metallic Inserts.

FEATURES

- One Set of Container Handling Changeparts
- 303/304 Stainless Steel Exterior
- 7' Long Sanitary Conveyor
- Main Control Console Component Box
- Allen-Bradley Compact/Control Logix PLC with
- Panel View 600 HMI
- 1 Hp DC Drive
- Plug and Cap Make Up and Back Up Detection
- Plug Vibratory Feed Bowl
- Cap Vibratory Feed Bowl
- No Plug No Cap Detection
- Left to Right Container Flow
- Operation and Maintenance Manual

OPTIONS

- Electronic Digital Vial Counter
- Remote access Programming
- Right to Left Container Flow Feature
- Spare Parts Kit
- Down Vial Eliminator
- Reject Station
- Container Make Up and Back Up Detection Front
- Panel Electronic Fill Volume Adjustment Filler
- Bypass System
- Servo Driven torquing Heads
- Lexan Enclosure

OPTIONAL LEXAN ENCLOSURE

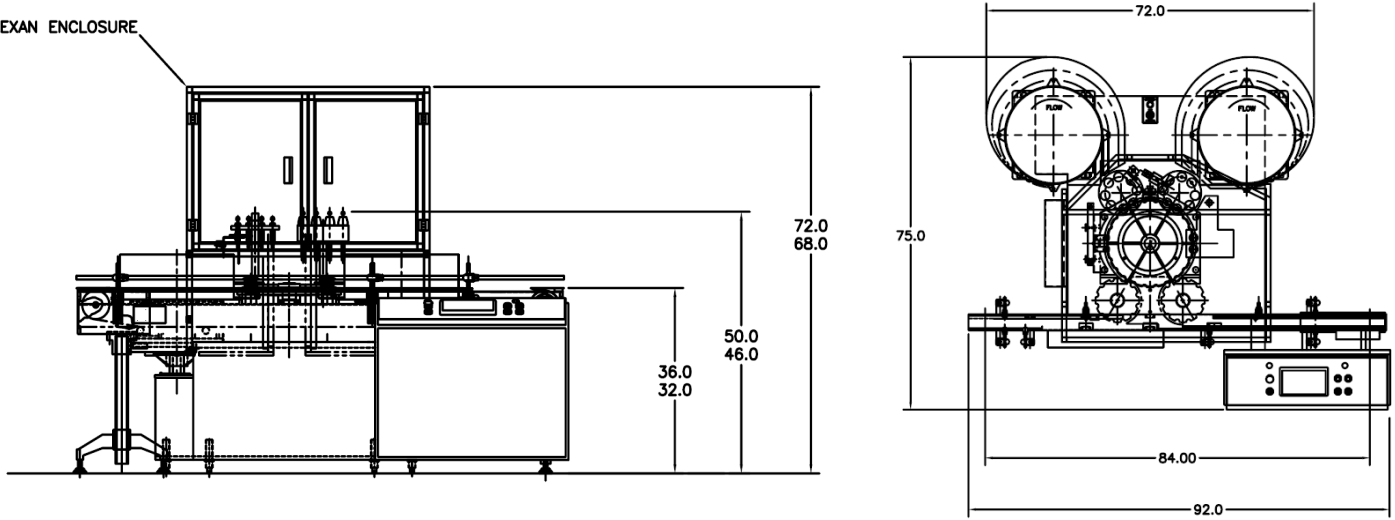

Approximate Dimensions W x D x H (Set up) 92" x 75" x 50" (2338mm x 1905mm x 1270mm) (does not include enclosure)

Approximate Dimensions W x D x H (Crated) 113" x 82" x 58" (2870mm x 2082mm x 1473mm)

Approximate Weight (Net) 3500 lbs. (159kg.) Approximate Weight (Gross) 4500 lbs. (2045kg.)

Model	Single Index	Dual Index	Triple Index	Quad Index
Functions	Fill – Plug – Screw Cap			
Filling Nozzles	1	2	3	4
Fill Volume Single Dose	Up to 120ml	Up to 120ml	Up to 60ml	Up to 30ml
Fill Volume Multiple Dose	Up to 360ml	Up to 360ml	Up to 120ml	Up to 60ml
Maximum Nozzle Elevation	Up to 3" (76mm)			
Closures Handled	Wipers – Ophthalmic Plastic – Stem Plug – Eye Dropper – and Others			
Minimum Closure Diameter Cap	5/16" (8mm)	5/16" (8mm)	5/16" (8mm)	5/16" (8mm)
Maximum Closure Diameter Cap	1 1/2" (38mm)	1 1/4" (32mm)	1" (25mm)	5/8" (16mm)
Minimum Closure Diameter Plug	5/16" (8mm)	5/16" (8mm)	1/4" (6mm)	1/4" (6mm)
Maximum Closure Diameter Plug	1 1/8" (29mm)	1 1/8" (29mm)	1" (25mm)	5/8" (16mm)
Closure Feeding	Vibratory Bowl			
Containers Handled	Straight – Side Round – Oval – Rectangular			
Minimum/Max. Container Height	1 1/4" to 6" (32mm – 152mm)			
Minimum/Max. Container Diameter	1/2" – 3 1/2" (13mm – 89mm)	3/8" – 2 3/8" (9mm – 60mm)	3/8" – 1 1/2" (9mm – 38mm)	1/4" – 1 1/8" (6mm – 29mm)
Containers Per Minute Output	Up to 55	Up to 110	Up to 165	Up to 220
Machine Cycles Per Minute	Up to 55			
Container Movement	Intermittent			
Container Spacing	5" (127mm)	2 1/2" (64mm)	1 5/8" (41mm)	1 1/4" (32mm)
Conveyor	3 1/4" (83mm) Delrin Raised Sanitary / 84" (2133mm) Long			
Main Motor Electricals	230V, 1Ph, 50/60Hz, 1Hp			
Controls Electricals	PLC			

